

## SPECIFICATIONS/DATA

Work Pad

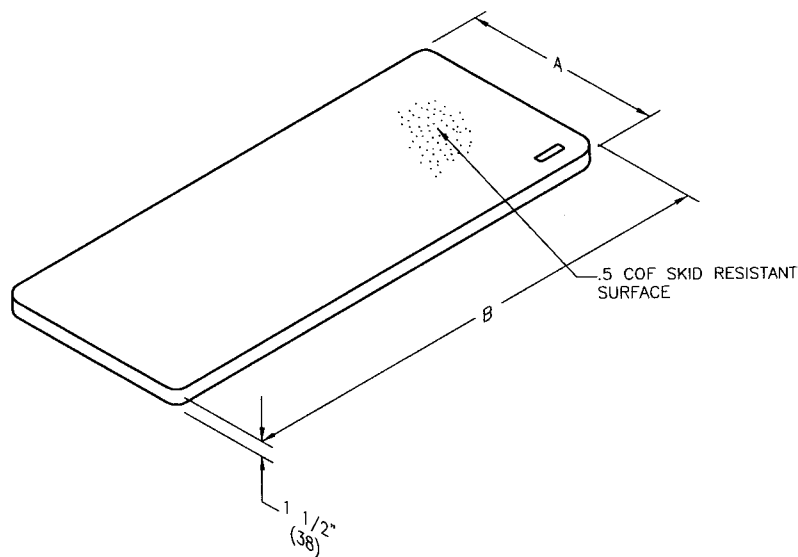

Cabinet shown mounted to a Quazite® traffic signal base along with three Quazite® underground enclosures.



PART NO.	OLD PART NO.	WEIGHT #	DIMENSION A	DIMENSION B
PH242500002T	PH2425AA	70 (30.8 kg)	24" (610 mm)	25" (635 mm)
PH243600002T	PH2436AA	95 (43.1 kg)	24" (610 mm)	36" (914 mm)
PH244400002T	PH2444AA	120 (54.4 kg)	24" (610 mm)	44" (1118 mm)
PH245800002T	PH2458AA	160 (72.6 kg)	24" (610 mm)	58" (1473 mm)

Dimensions & weights in parentheses are metric equivalent.