

EAGLE SPAN WIRE SUSPENSION TWO-WAY (ALUMINUM) BULLETIN 2402

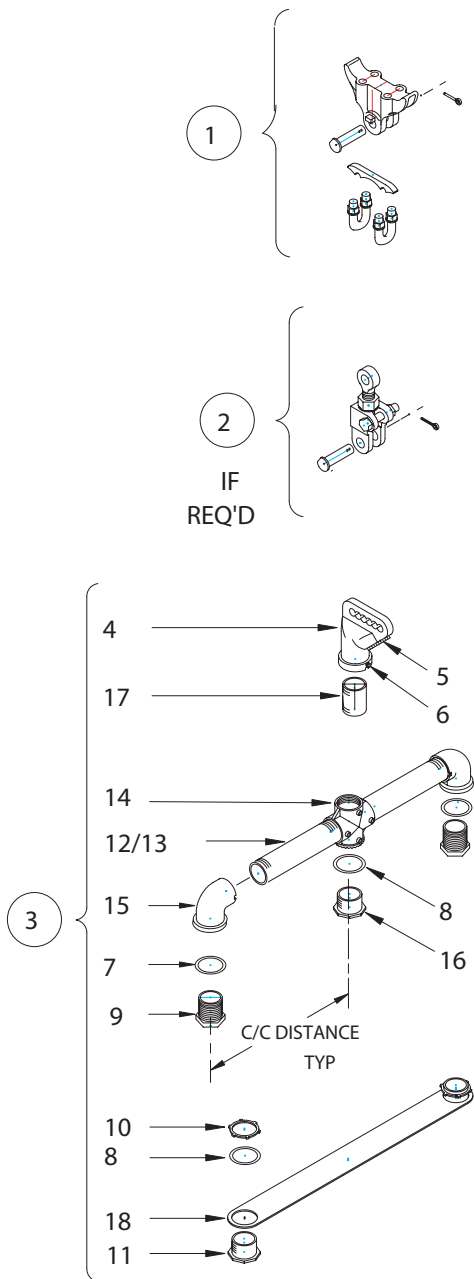

ITEM	DESCRIPTION	PART NO.
①	CABLE SUSPENSION CLAMP	A21926
②	BALANCE ADJUSTER	A32000
③	2-WAY TOP & BOTTOM	A24128X
	2-WAY TOP BRACKET ASSEMBLY	U2221x*
	2-WAY BOTTOM BRACKET ASSEMBLY	L2201x*
4	WIRE ENTRANCE	M22162
5	INSULATOR BUSHING	M10738
6	SET SCREW (1/4-20)	M50163
7	NEOPRENE WASHER	M60615
8	FLAT WASHER	M30473
9	LOCK NIPPLE	M22241
10	CONDUIT NUT	M31040
11	ORNAMENT CAP	M20872
12	PIPE ARM FOR 8.5 C/C	A70058005.75
13	PIPE ARM FOR 10.5 C/C	P261050
14	CROSS, SERRATED	TB21118
15	ELBOW, SERRATED	M21111
16	ORNAMENT CAP	M20816
17	NIPPLE	P280250
18	2 WAY TIE BRACE	A7021497 (for B)

*Bulletin 2402x

*x = "B" for 8½" C/C distance
x = "D" for 10½" C/C distance