

EAGLE POST TOP BRACKET TWO-WAY VERTICAL (IRON) BULLETIN 2206

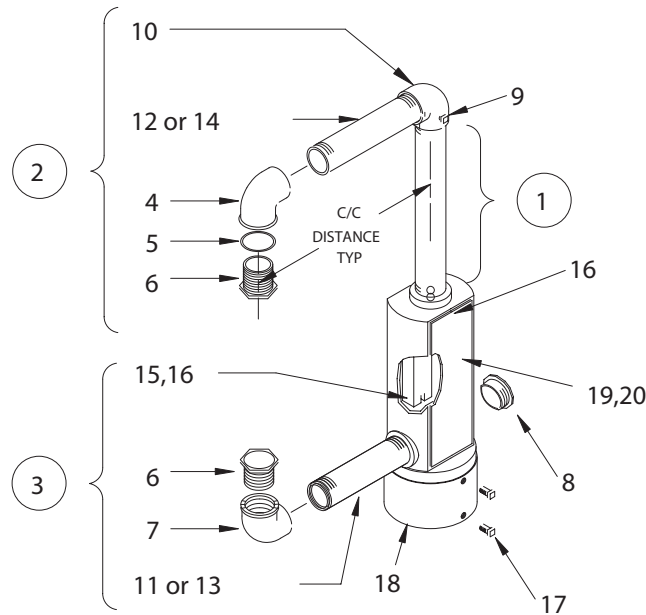

ITEM	DESCRIPTION	PART NO.	ITEM	DESCRIPTION	PART NO.
①	CENTER PIPE SUPPORT SPECIFY SIGNAL CONFIGURATION		10	ELBOW (SLIP-FIT)	M31106
②	1-WAY TOP BRACKET ASSEMBLY	U3119x*	11	PIPE ARM FOR 8.5 C/C	P360650
③	1-WAY BOTTOM BRACKET ASSEMBLY	L3119x*	12	PIPE ARM FOR 8.5 C/C	P360750
4	ELBOW (PLAIN)	M31110	13	PIPE ARM FOR 10.5 C/C	P360850
5	GASKET	M60615	14	PIPE ARM FOR 10.5 C/C	P360950
6	LOCKNIPPLE	M32241	15	TERMINAL BLOCK	M13604
7	ELBOW (SERRATED)	M31111	16	SCREW (#10-32)	M50105
8	ORNAMENT CAP	M20816	17	SET SCREW (3/8-16)	M50120
9	SET SCREW (1/4-20)	M50163	18	TERMINAL COMPARTMENT	M33512
			19	COVER	M23306
			20	GASKET	M60606

*Bulletin 2206x

*x = "B" for 8½" C/C distance
x = "D" for 10½" C/C distance