

### Function

The EAGLE Utility cabinet protects electronic components including controllers and other instruments.

### Features

The EAGLE Utility cabinet features an aluminum enclosure for protection from all forms of outdoor natural elements, including rain, sleet, and snow, as well as seepage and splash. U.L. listed.

### Specifications

#### Enclosure

1. Completely fabricated from .125"-thick type 5052-H32. Vinyl-coated, mill finished aluminum utilizing intermittently welded construction, subsequently weatherproofed with silicone sealant.
2. Internal attaching components include four (4) standoffs on rear wall for panel mounting.
3. The door opening single-flanged on all 4 sides.
4. Thermoconvection air ventilation system utilized.
5. All internal and external hardware utilizes non-corrosive material.



#### Door

1. Main door lock - standard police lock.
2. Closed-cell neoprene door seal gasket used.
3. Heavy gauge aluminum butt hinge utilizing a non-removable 3/16" -diameter stainless steel hinge pin for door support, carriage bolted in place for ease of door removal.

## Cabinet Diagram

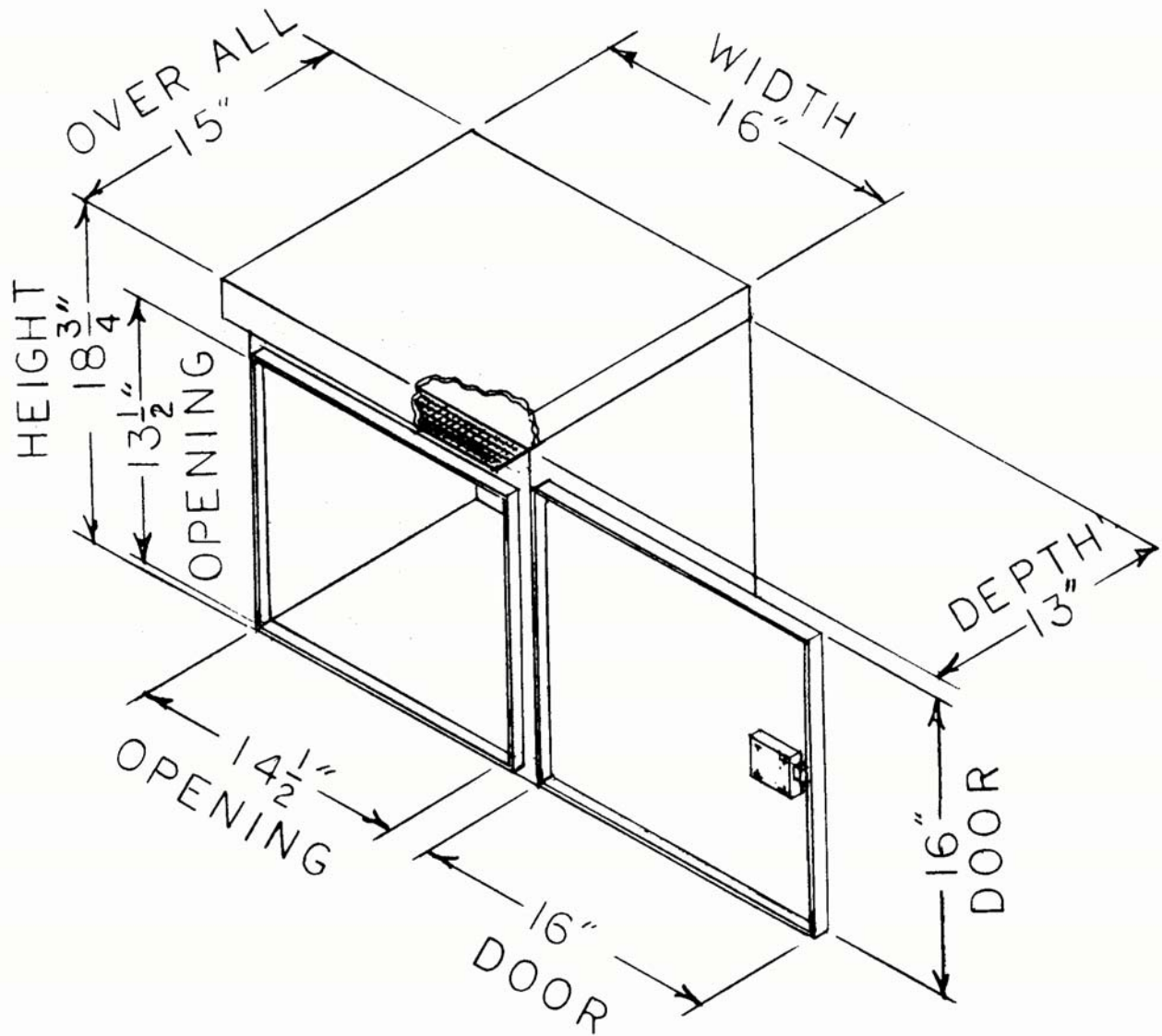

### Options

1. Main door lock with dust cover.
2. Continuous welded enclosure for maximum contaminant protection.
3. Heavy gauge stainless steel continuous hinge utilizing a non-removable 3/16"-diameter hinge pin.
4. Special paint per customer requirements.

### Ordering Information

CATALOG NO.	DESCRIPTION
EL 730	Standard
EL 731	Lock w/dust cover